

Origami beach table and sun lounger instructions

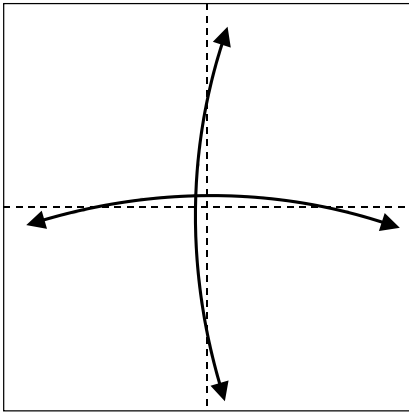

1. Place design face down and fold in half twice to make crease

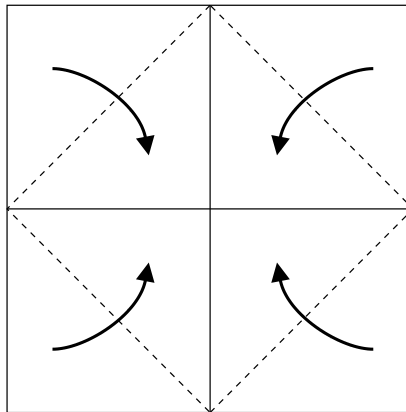

2. Fold corners into middle along dotted lines to make creases

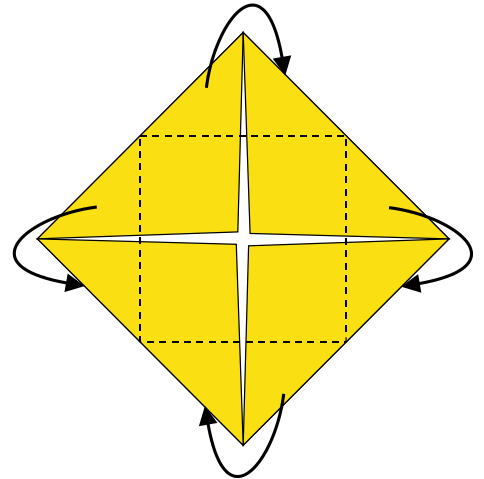

3. Fold backward over the dotted lines

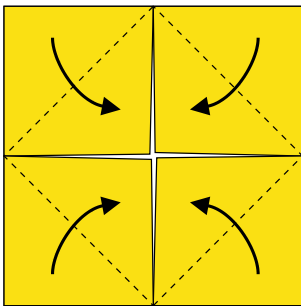

4. Fold corners to middle over the dotted lines

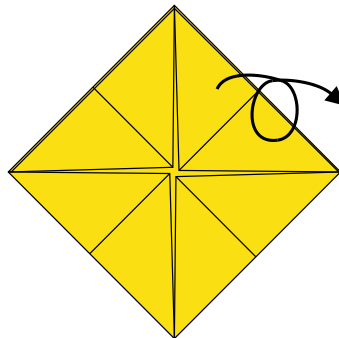

5. Turn over

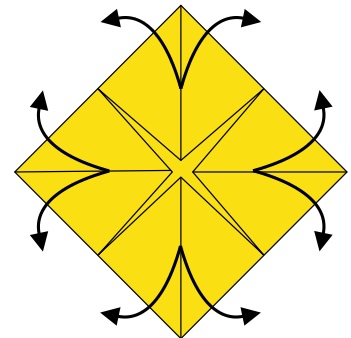

6. Open out flaps and flatten to form rectangle

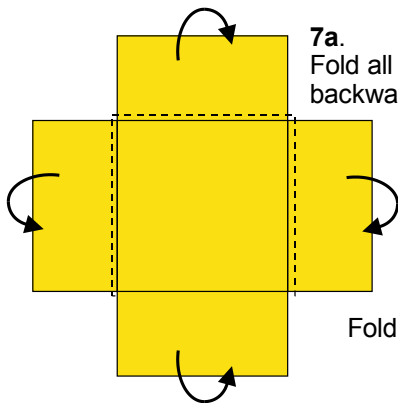

7a. Fold all rectangular flaps backwards to make table

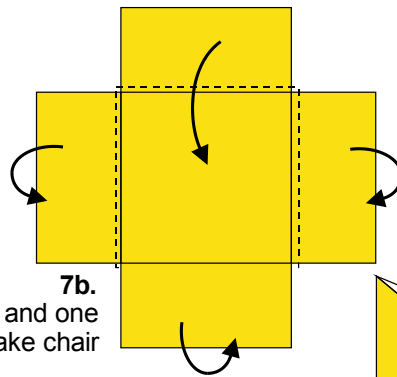

7b. Fold 3 flaps backwards and one forward to make chair

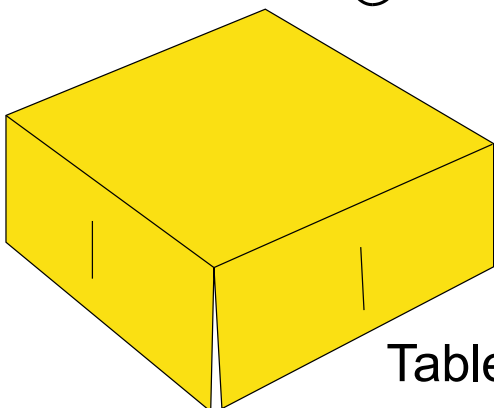

Table

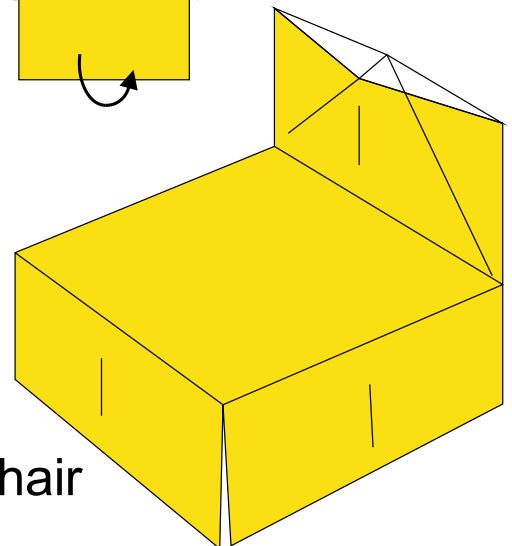

Chair

Origami Parasol instructions

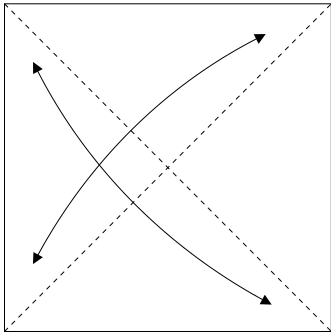

1. Place design face down and fold diagonally in half twice to make creases

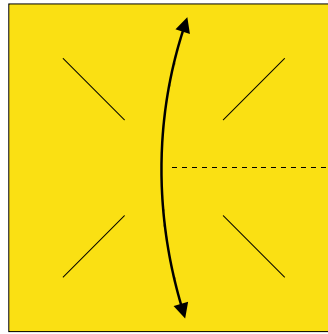

2. Turn over and crease only over half the square (dotted line)

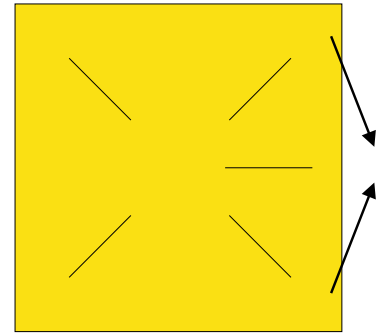

3. Bring together the pieces to form parasol

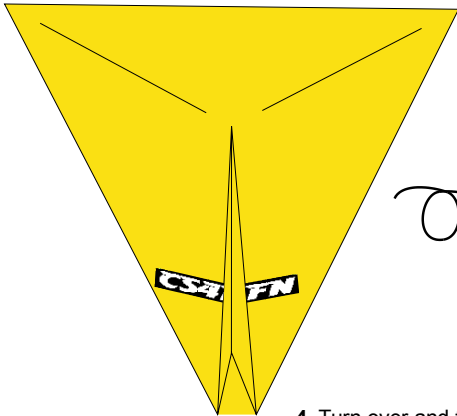

4. Turn over and fold inner flap in half

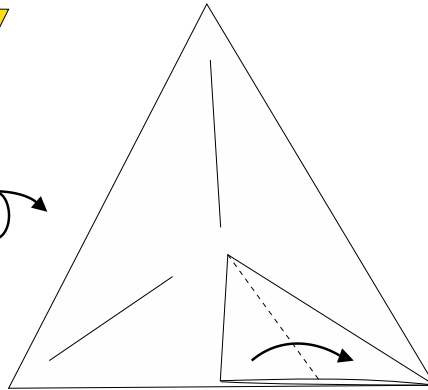

5. Fold flap in half again

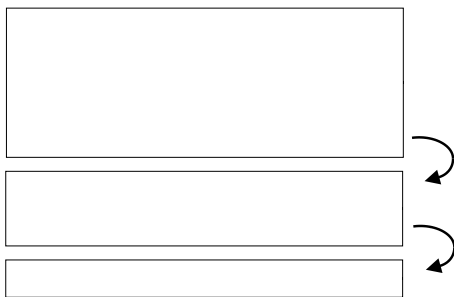
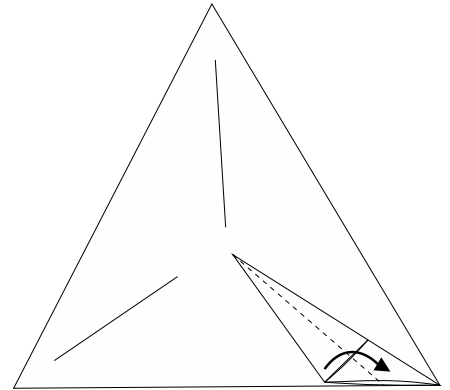

6. Take remaining rectangle piece and hold in half 3 times

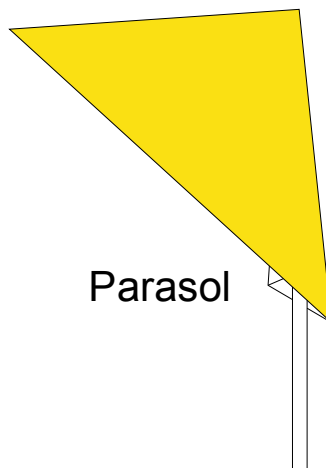

Parasol

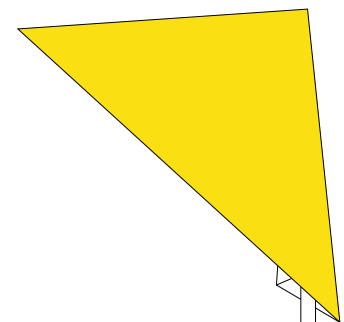

8. Insert parasol into side flap of table

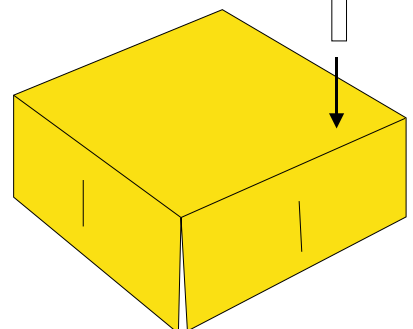

7. Insert folded rectangle into inner parasol flap